

PREFORMED TWF END DAMS

1. DESCRIPTION

Polyguard Preformed TWF End Dams (TWF End Dam) are designed to close a flashing at a discontinuous end. They are designed to fit into masonry coursing heights of 2-inches or more without trimming and to be trimmed to fit veneer depths, including the cavity, up to 8-inches, 6-inches illustrated. Rotating a **TWF End Dam** along the length axis allows it to be used at either the left or right end of a flashing.

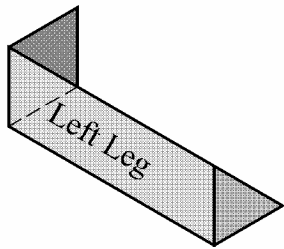

Left 6-inch Preformed TWF End Dam

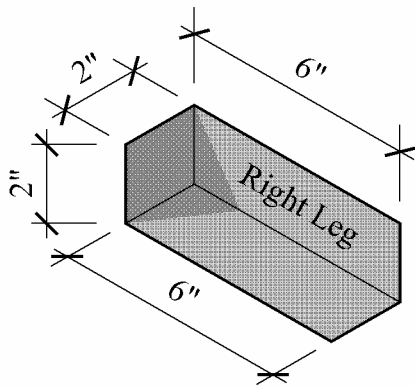

Right 6-inch Preformed TWF End Dam

2. LIMITATIONS

None when used for the design purpose.

3. MATERIALS AND COMPOSITION

Polyguards 40mil proprietary asphalt compound bonded to a polyethylene sheet.

4. PHYSICAL PROPERTIES

Thickness	40 mils
Puncture Resistance – Film (ASTM D-781) Kg/CM	110
Puncture Resistance of Composite Membrane (ASTM E-154) LBS	40 Min.
Tensile Strength of Composite Membrane (ASTM-D-412 Modified Die C)	750 PSI Min.
Elongation-Ultimate Failure of Rubberized Asphalt (ASTM-D-412 Modified Die C)	400% Min.
Water Vapor Transmission (Permeance) (ASTM-E-96 Method B) (Grains/Sq.Ft./Hr. in HG)	0.035 Max
Water Absorption (ASTM-D-570)	.014%

5. CHEMICAL RESISTANCE

Not chemically affected by metal, cement, or clay materials used in masonry wall construction.

6. TECHNICAL DATA

Polyguard Products, Inc. provides design data and installation instructions to architects, engineers, specifiers, and contractors.

7. INSTALLATION

Example for 6-inch **Preformed TWF End Dam**, substitute 8-inches for 6-inches as applicable: Remove the release paper and adhere the 2-inch by 6-inch horizontal leg to the under-flashing, adhere the 2-inch by 2-inch leg to the backing wall, and embed the 2-inch by 6-inch vertical leg into a head joint. Trim the forward edge to 5-8-inch from the bend in an associated drip edge. Apply pressure over the face of the adhered vertical and horizontal legs of the **End Dam** with a rubber roller.

Storage: Protect the material from heat, crushing, moisture, mud, and construction dirt. Keep the product in the box until it will be used. For best results, the material should be stored between 50 to 75 degrees F prior to application.

Preparation: Prepare the surfaces that will bond with the 2-inch by 2-inch vertical leg and 2-inch by 6-inch horizontal leg so that, they are smooth relative to the construction surface, clean and dry.

Safety: Material Safety Data Sheets are available upon by phone, e-mail, or on the web.

Product Attachment: Test for adhesion. If the *TWF End Dam* can be separated from the substrates without deforming the flashing a liquid or spray adhesive will be needed. In that event, apply either a liquid adhesive, at a rate of 250-300 sq. ft. per gallon, or a spray tack coat, to the surfaces that will receive the flashing. Use a liquid or spray adhesive that is compatible with the substrates. Choose one of the following: solvent based *Polyguard 650LT*, (in California, *Polyguard California Sealant*) for substrates that are compatible with solvent based material, *Polyguard Shur-Tac* for substrates that are not compatible with solvent based materials, or *Polyguard 343 Spray Adhesive*.

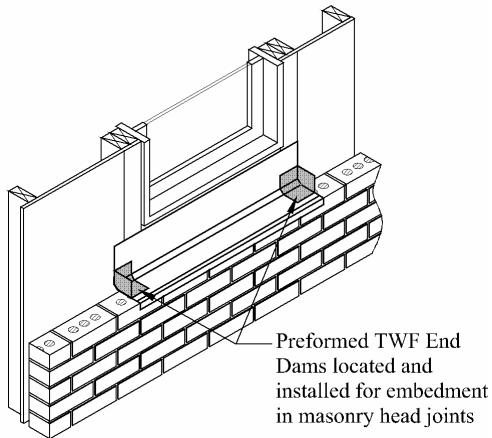

TWF End Dams in Sill Flashing

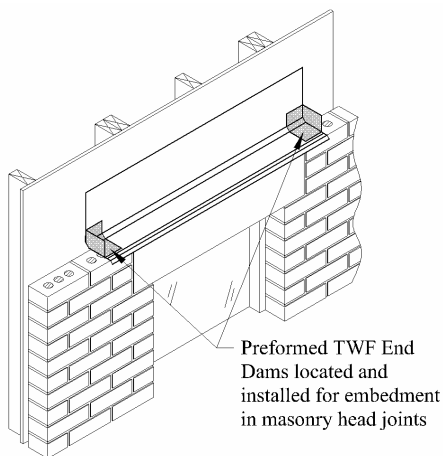

**TWF End Dams in Steel Angle or Lintel Flashings,
Lintel Shown**

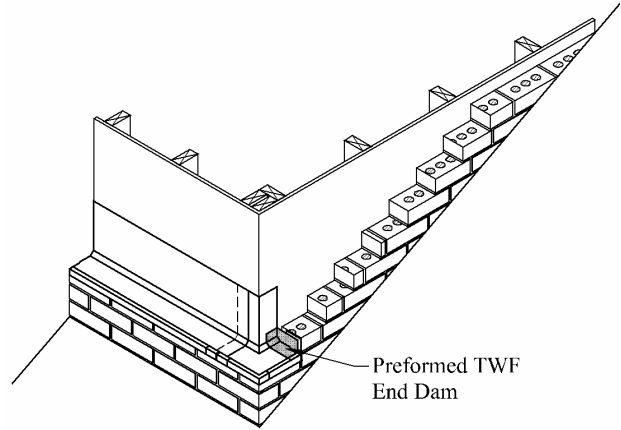

TWF End Dams in Roof to Wall Flashing

8. AVAILABILITY AND COST

Polyguard Preformed TWF End Dams are packaged 50 per box.

Information about a distributor near you is available by phone or e-mail.

9. GUARANTEE

Polyguard Preformed TWF End Dams will meet published specifications at the time of delivery.

10. TECHNICAL SERVICES

Polyguard Products, Inc. offers specialist advice to aid the architect, engineer, and contractor with the construction process.

© Polyguard Products 2011

X:/Lit/Arch/2011/TWF Preformed End Dams.doc R.3-3-11