

INSTALLATION INSTRUCTIONS

TOTAL-FLOW AND FLOW 15-P

Prefabricated Soil Sheet Drain

REQUIRED MATERIALS

1. 2' X 50' rolls of TOTAL-FLOW sheet drain.
2. 4' x 50' rolls of FLOW 15P sheet drain, if full wall drainage is required.
3. TOTAL-FLOW sheet drain corner guards
4. 3" wide underground tape
5. Attached materials (see below)
6. Knife or scissors, rubber hammer.

DRAIN ATTACHMENT METHODS

For attaching drain to waterproofing material, concrete or wood, several methods may be used including metal stick pins, nails driven through washers or wood lathing, construction adhesives or double sided tape. Discuss materials compatibility with waterproofing supplier before adhesives. Typically any method used for attaching waterproofing protection board will work for drain. For attaching drain to bare earth, 4-8" anchor pins with washers work well.

CLEAN WALL / WATERPROOF / INSULATE

Clean wall and apply waterproofing or insulation if required.

INSTALLING FIRST ROW OF DRAIN (The TOTAL-FLOW sheet drain row)

The first row of drain to be installed is the TOTAL-FLOW at the bottom of the wall. The drain should sit on top of the footing with the high profile part of the drain at the bottom to provide high lateral water flow.

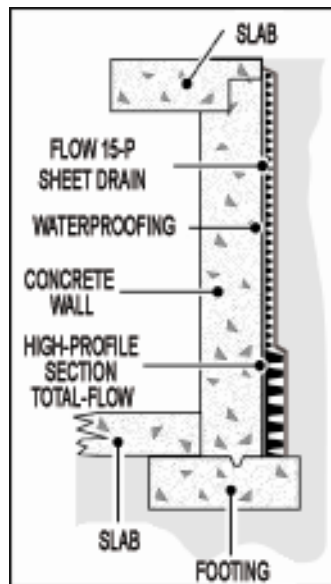

If not using Flow 15-P sheet drain for full wall coverage, close the top end of the drain to prevent soil intrusion by folding the fabric behind the drain. Close the high profile section with 3" underground tape.

INSTALLING NEXT ROLL OF FLOW

To attach the next roll of TOTAL-FLOW drain, cut one row of low-profile dimples from each end of the two sections to be joined. Do not cut fabric. Interlock one row of the high-profile section and secure connection. Overlap fabric and apply 3" wide underground tape from the top to the bottom of the joint to prevent soil intrusion.

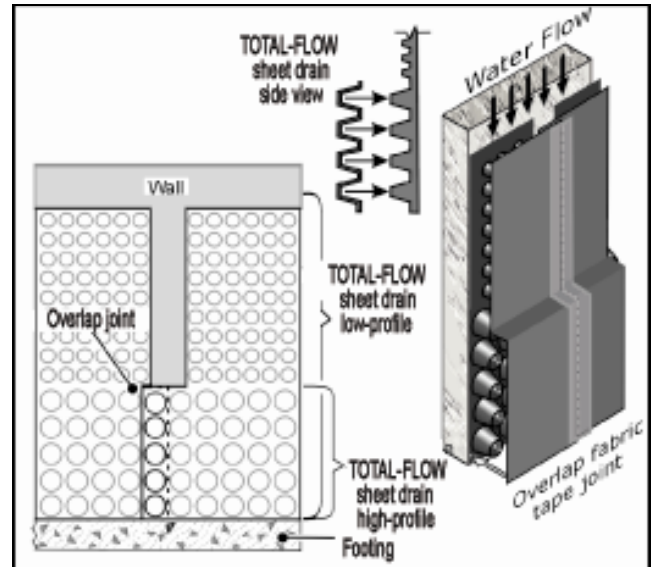

GOING AROUND CORNERS

Bend drain to make inside corners. For outside corners, cut the low-profile core flush with corner and tape edges. Slit fabric on high-profile section, bend around corner, and place guard with fabric over slit in high-profile drain. Secure with underground tape.

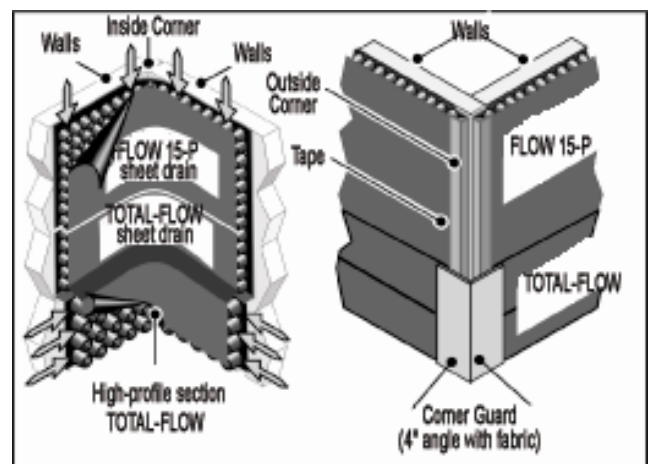

This Information is based on our best knowledge, but POLYGUARD cannot guarantee the results to be obtained.

POLYGUARD PRODUCTS, INC • ENNIS, TEXAS 75120-0755

PH: 214-515-5000 • 800-541-4994 • FAX: 972-875-9425

Web Site: www.polyguardproducts.com



INSTALLATION INSTRUCTIONS

TOTAL-FLOW AND FLOW 15-P

Prefabricated Soil Sheet Drain

CONNECTING FLOW 15-P SHEET DRAIN:

If full wall drainage is required, FLOW 15-P soil sheet drain is attached above the TOTAL-FLOW sheet drain. The FLOW 15-P may be installed either horizontally or vertically.

VERTICAL WALL:

When the FLOW 15-P sheet drain is installed vertically, the flange should be facing the direction opposite if the TOTAL-FLOW water flow. When the FLOW 15-P sheet drain is installed horizontally, the edge of the core with the flange should be at the top. This flange position, similar to roof shingle applications, minimizes seepage of water behind the drain. Fold back the fabric at the top of the TOTAL-FLOW sheet drain and place the FLOW 15-P sheet drain on top of the TOTAL-FLOW core and flange. Fold fabric from sheet drain section down over the TOTAL-FLOW section and secure with 3" tape.

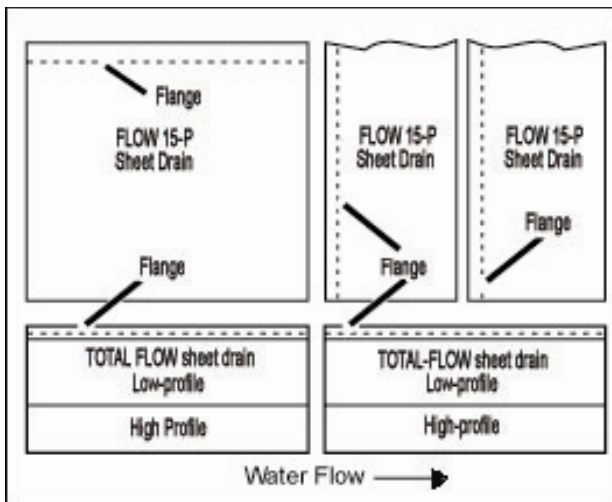

PIPE COLLECTION SYSTEM:

For foundation walls where a drain pipe will be used, position lower end of core horizontally on ground. Peel back fabric to allow drainage pipe to rest on core. Tuck fabric around drainage pipe and under core. Place small amount of select backfill material on fabric to hold in place until backfill is completed.

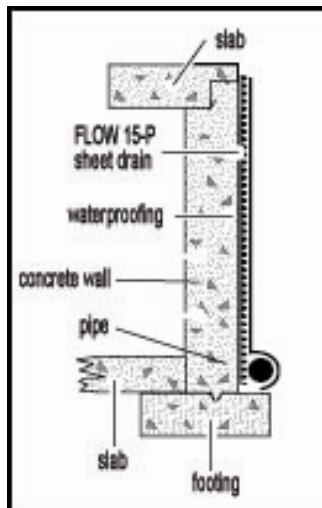

ATTACHING NEXT ROLL OF FLOW 15-P:

There are two acceptable methods for joining two sections of sheet drain.

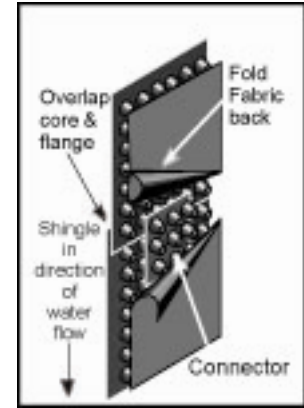
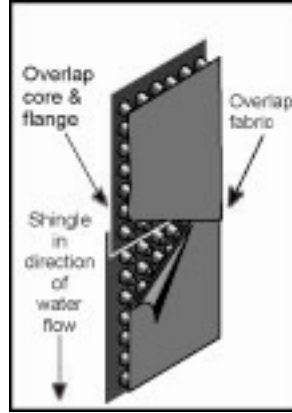

METHOD #1

Fold back edge of fabric on lower (or downstream) drain. Do not detach from dimples. Place cones of upper (upstream) drain over flange of lower drain. Overlap fabric of upper drain over lower drain. Seal seam with 3" tape.

METHOD #2

Overlap drain core as shown at right. Peel back fabric exposing two rows of cones. Place cones of upper (upstream) drain over flange of lower drain. Overlap fabric of upper drain over lower drain.

OPTIONAL METHOD

For either method, overlap fabric in direction of water flow. Use tape or spray adhesive, if necessary, to keep fabric at joint in place prior to backfilling. All edges of drain should have extra fabric tucked behind core edge to prevent soil from entering core.

NOTE:

The non-woven fabric is bonded to the core on the flange side with permanent glue (will not adhere if pulled from core) and on the flush side away from the flange with pressure sensitive glue (will re-adhere if pressure is applied). The pressure sensitive glue permits the fabric to be peeled back easily to be placed around pipes. Woven fabric is attached with all pressure sensitive glue. Permanent glue can be softened, if necessary, with a blow drier. Do not use near open flame to avoid damaging the fabric.

INSTALLATION INSTRUCTIONS

TOTAL-FLOW UNIVERSAL FITTINGS

UNIVERSAL TEE FITTINGS

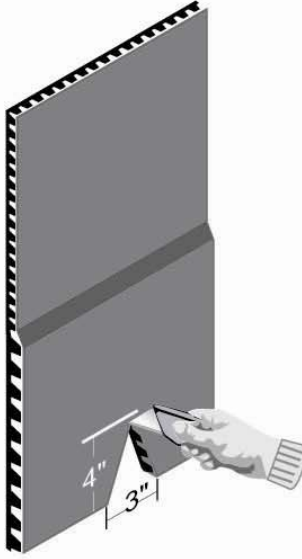

STEP # 1

Use razor knife and cut a V-notch in the bottom portion of the TOTAL-FLOW approximately 3" wide at the bottom and 4" high and discard

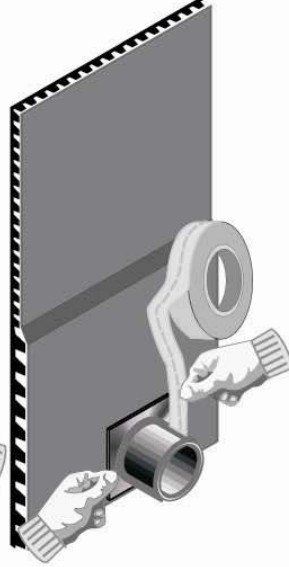

STEP # 2

Insert fitting over notch and tape bottom of the TOTAL-FLOW

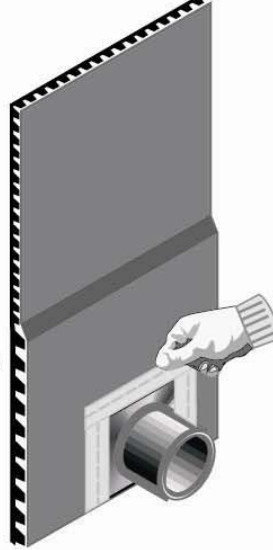

STEP # 3

Make sure all edges of fitting are covered with tape

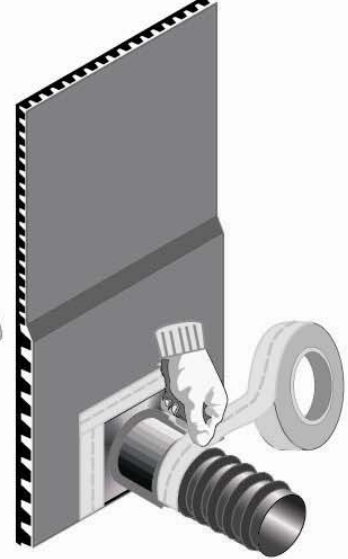

STEP # 4

Insert pipe into fitting and secure with tape

UNIVERSAL OUTLET FITTINGS

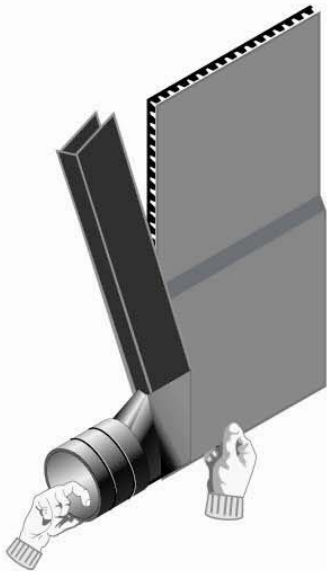

STEP # 1

Place end outlet over bottom corner of TOTAL-FLOW with fabric up

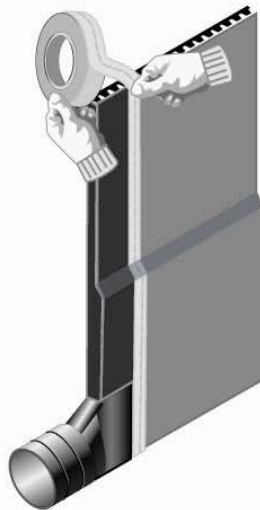

STEP # 2

Fold fabric around exposed edge of core and tape with 3" underground tape

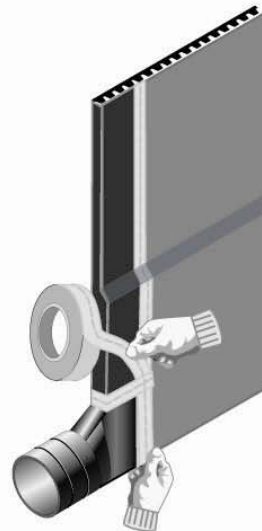

STEP # 3

Secure all edges with 3" tape to prevent soil intrusion

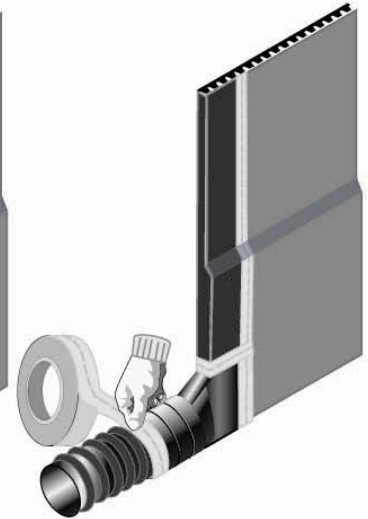

STEP # 4

Insert 4" pipe into end of outlet and secure connection with 3" tape

INSTALLATION INSTRUCTIONS

TOTAL-FLOW UNIVERSAL FITTINGS

GOING AROUND CORNERS

Bend drain to make inside corners. For outside corners, cut and bend drain core to reach corner and provide 3" of extra fabric to wrap around corner. Attach drain to wall and overlap fabric at joint.

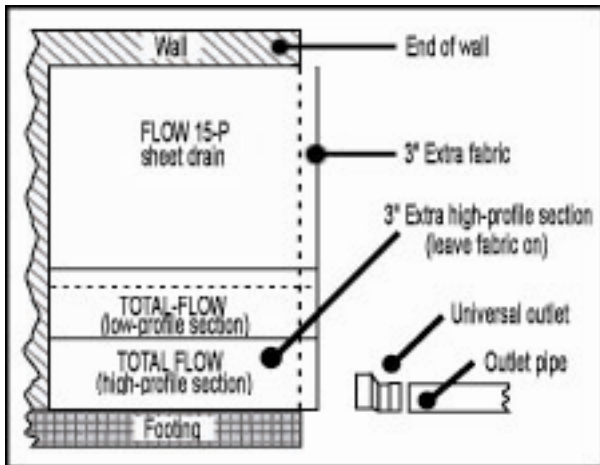

RETAINING WALLS- (see Figure 1)

Cut bottom of drain to match bottom of wall. (Cut 1/2" diameter holes in flat back of core, opposite fabric) at weep locations. **DO NOT CUT FABRIC.** Place drain on wall fabric toward soil. Tuck extra fabric at downstream edge of core. Attach drain with appropriate attachment method.

SHORING WALLS - (see Figure 2) Place drain with fabric side toward soil to be drained. Cut 1/2" diameter holes on flat back of core at discharge pipe location. **DO NOT CUT FABRIC.** Concrete or gunnite/shotcrete may be placed directly against the core side of the drain.

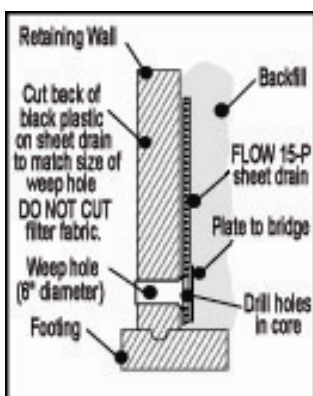

FIGURE 1

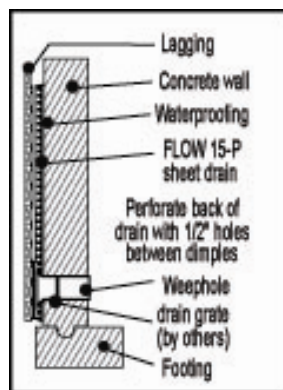

FIGURE 2

SEALING EDGES:

All edges of drain should have extra fabric tucked behind core edge seal to prevent soil from entering core.

BACKFILLING:

Soil should be placed and compacted directly against the drain. Direct compactor exhaust away from the drain to prevent damage. Backfill to a minimum of 6" above drain to allow for coverage after settlement.

FOR HORIZONTAL PLAZAS- (see Figure 3)

Place drain with fabric side up. Cut core and fabric to fit tightly around floor drain.

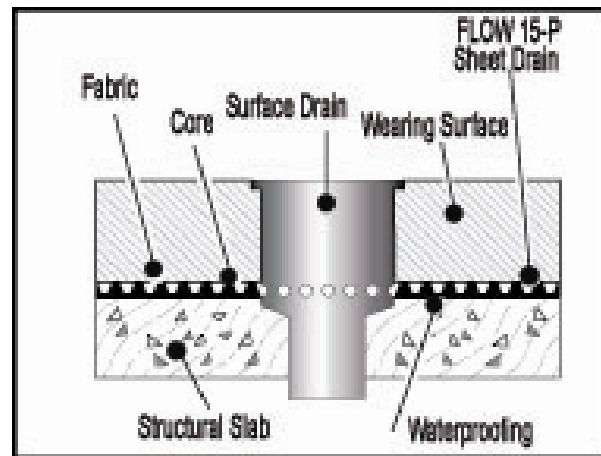
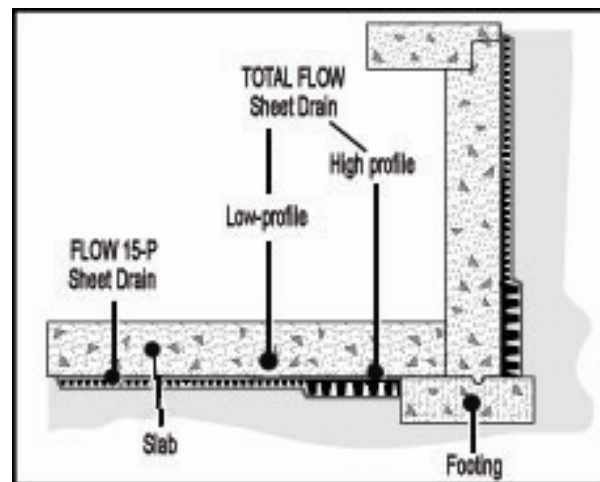

FIGURE 3

INSTALLATION UNDER SLABS

For under floor slab installation, position TOTAL-FLOW sheet drain as shown with geotextile to soil side. Waterproofing and/or floor slab can be applied directly to the back of the core.



QUANTITY TO ORDER:

It is suggested that in the absence of exact information on the amount of material required, add 5% to the estimated quantity.