

PLACE OUTSIDE CORNER BOOT ONTO CONCRETE FORM ASPHALT SIDE OUT - KEEP CLEAN FOR ADHESION OF TERM UNDERSLAB FIELD APPLIED CORNER PIECES

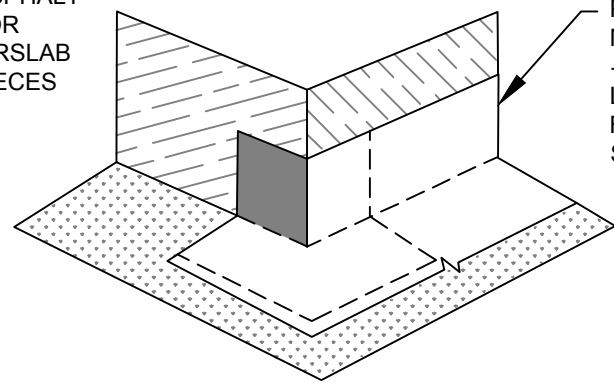

PLACE FIRST TERM UNDERSLAB MEMBRANE LEG VERTICALLY ON FORM - CUT VERTICALLY IN THE CORNER, LAYING TERM UNDERSLAB MEMBRANE FLAP HORIZONTALLY ONTO ASPHALT SIDE OF CORNER BOOT

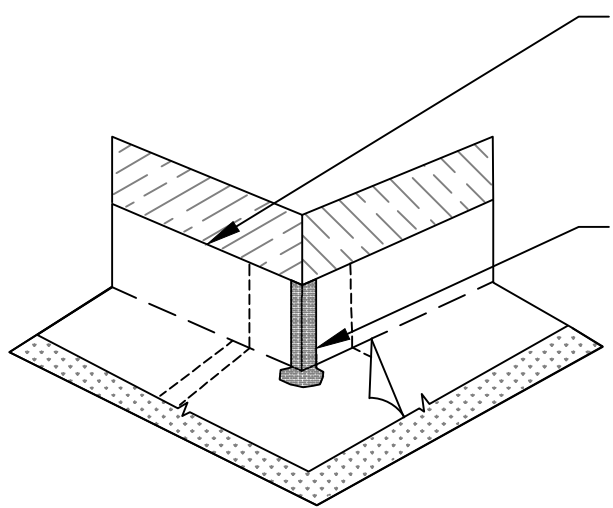

PLACE SECOND LEG ON OPPOSITE SIDE OF CORNER - CUT VERTICALLY IN THE CORNER, LAYING TERM UNDERSLAB MEMBRANE FLAP ONTO THE PREVIOUS-APPLIED TERM UNDERSLAB MEMBRANE

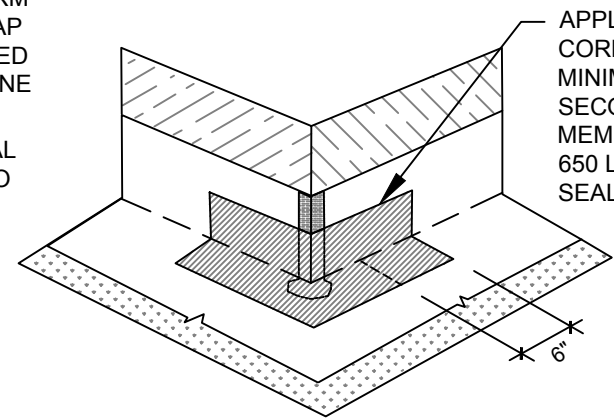

APPLY LM-95 OVER VERTICAL CUTS AT CORNER AND ONTO HORIZONTAL MEMBRANE A MINIMUM OF 2" IN ALL DIRECTIONS - PREPARE FABRIC WITH 650 LT LIQUID ADHESIVE OR CALIFORNIA SEALANT AT A RATE OF 50 - 75 SF / GAL

APPLY FABRIC TAPE TO INSIDE CORNER AND OVER CURED LM-95 A MINIMUM OF 6" BEYOND CUT OF SECOND PIECE OF TERM UNDERSLAB MEMBRANE - PREPARE FABRIC WITH 650 LT LIQUID ADHESIVE OR CALIFORNIA SEALANT AT A RATE OF 50 - 75 SF / GAL

TU19

TERM<sup>®</sup> UNDERSLAB WATERPROOFING / TERMITE BARRIER - OUTSIDE CORNER (FIELD CUT)

©POLYGUARD PRODUCTS, INC.

**Polyguard**  
 Innovation based. Employee owned. Expect more.  
 P.O. Box 755 - Ennis, TX 75120  
 Phone: 214-515-5000 Fax: 972-875-9425  
 Web Site - www.polyguardbarriers.com



The information provided is based on data and knowledge considered to be true and accurate and is offered for the users' consideration, investigation, and verification; but we do not warrant the results to be achieved. Please read all data sheets, statements, suggestions, or recommendations in conjunction with our conditions of sale, which apply to all goods supplied by us.

DRAWING SCALE:	NOT TO SCALE
EFFECTIVE DATE:	03/01/2019
SUPERCEDES:	NONE